

seca 704/seca 703

seca 703 s

Instructions for Use

17-10-07-683-002-2026-03S

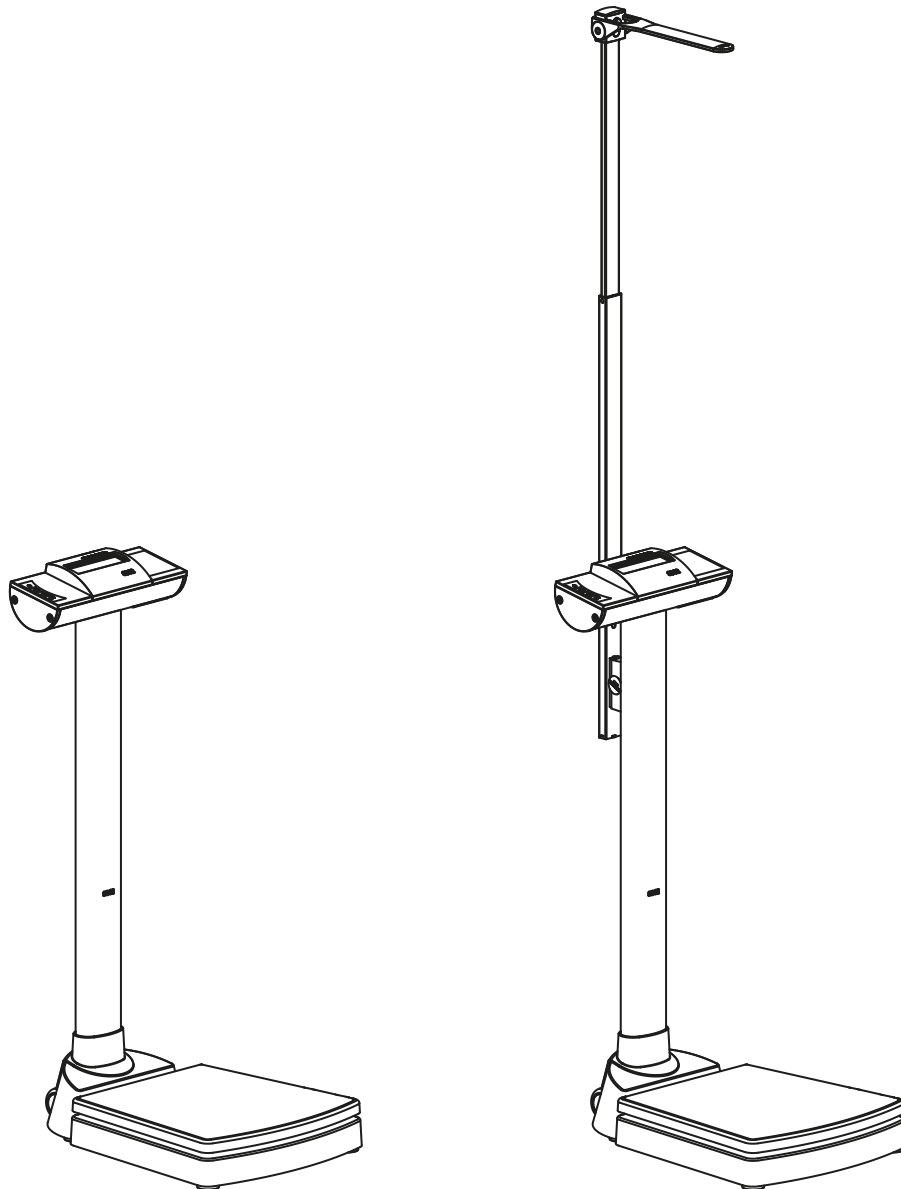

TABLE OF CONTENTS





1 About this document	3	5.6	Aligning the scale	19
1.1 Representation in text	3	5.7	Moving the scale	20
1.2 Representation in diagrams	3	5.8	Fitting the measuring rod	20
1.3 Devices in this document	3		Fitting the spacer.....	20
2 Description of device	4		Fitting the stadiometer	20
2.1 Intended use.....	4		Checking the installation height	21
704/703	4		Correcting the installation height	22
703 s.....	4	6 Operation	22	
2.2 Contraindications	4	6.1 Weighing.....	23	
2.3 Clinical benefit.....	4	Switching on the scale	23	
704/703	4	Weighing a patient.....	23	
703 s.....	4	Weighing babies/toddlers (2 in 1).....	23	
2.4 Patient target group.....	4	Keep the measuring result on the display (HOLD).....	23	
2.5 User qualification.....	4	Determining Body Mass Index	24	
Assembly	4	Switching weighing range automatically ..	24	
Operation.....	4	Switching the weight unit (UnIt).....	24	
Administration/network operation	4	Switching off the scale	25	
2.6 Functional description	4	6.2 Measuring height (variant-dependent)	25	
Measuring weight	4	Measuring heights up to 130.5 cm.....	25	
Measure height.....	4	Measuring heights above 130.5 cm	25	
External interface module (optional accessory)	5	6.3 Other functions (menu).....	26	
seca connect 103 software (optional accessory)	5	Deleting saved values automatically (ACLR).....	26	
3 Safety precautions	5	Saving additional weight permanently (Pt)	26	
3.1 Safety information in these instructions for use.....	5	Activating Autohold function (AHOld).....	27	
3.2 Basic safety information.....	5	Activating/deactivating beeps (bEEP)	27	
Handling device.....	5	Setting filtering (FIL).....	27	
Preventing electric shock	6	Non-verified models: Switching the weight unit (UnIt)	28	
Preventing injuries and infections.....	7	Restoring factory settings (rESet)	28	
Preventing damage to device.....	8	7 Hygiene treatment	29	
Handling measuring results.....	8	7.1 Cleaning	29	
Handling packaging material.....	9	7.2 Disinfecting.....	29	
Handling batteries and rechargeable batteries.....	9	7.3 Sterilizing.....	29	
4 Overview	10	8 Function check	30	
4.1 Controls, scale.....	10	9 Troubleshooting	30	
4.2 Controls measuring rod (variant-dependent)	11	10 Servicing	31	
4.3 Symbols in the display	12	10.1 Verified scales	31	
4.4 Markings on the device and on the type plate.....	12	10.2 Non-verified scales.....	32	
4.5 Menu structure	15	10.3 Measuring rod	32	
4.6 Navigating in the menu.....	15	11 Technical data	32	
5 Starting up device	16	11.1 General technical data	32	
5.1 Scope of delivery, scale	16	11.2 Weight measurement	33	
5.2 Scope of delivery, measuring rod.....	16	11.3 Height measurement	34	
5.3 Fitting the column (seca 704)	17	12 Optional accessories and spare parts	34	
5.4 Fitting the column (seca 703, seca 703 s)....	18	13 Compatible seca products	35	
5.5 Establishing power supply	18	14 Disposal	35	
Inserting batteries.....	18	14.1 Disposing of the device.....	35	
Connecting the power supply unit (optional).....	19	14.2 Disposing of batteries and rechargeable batteries.....	35	
		15 Warranty	35	
		16 Declaration of conformity	36	

1 ABOUT THIS DOCUMENT

1.1 Representation in text

Symbol	Description
✓	Requirement for actions
▶	Action
1. 2.	Actions with specified sequence
a) b)	Steps of an action with specified sequence
⇒	Result of an action
• •	First level of a list
– –	Second level of a list

1.2 Representation in diagrams

Symbol	Description
	Indicates directions of movement of the device or of device components
	Navigation path in menu displays
	<ul style="list-style-type: none"> • Correct action • Correct result of action
	<ul style="list-style-type: none"> • Incorrect action • Incorrect result of action
	End of a procedure, e.g. the installation of a part

1.3 Devices in this document

This document applies to the following devices:

- **seca 704:** Verified scale
- **seca 703:** Non-verified scale
- **seca 703 s:** Measuring station (non-verified scale with telescopic measuring rod)

2 DESCRIPTION OF DEVICE

2.1 Intended use

704/703 The electronic column scale supports physicians in making a diagnosis or deciding on a course of treatment based on weight or weight change.

703 s The measuring station supports physicians in making a diagnosis or deciding on a course of treatment based on weight, height, or changes in the measured parameters.

2.2 Contraindications

No contraindications are known.

2.3 Clinical benefit

704/703 The electronic column scale supports physicians in making a diagnosis or deciding on a course of treatment based on the weight measured.

The electronic column scale thus delivers only an indirect clinical benefit.

The physician must perform additional examinations for an accurate diagnosis.

703 s The measuring station supports physicians in making a diagnosis or deciding on a course of treatment based on the patient's weight or height.

The electronic measuring station thus delivers only an indirect clinical benefit.

The physician must perform additional examinations for an accurate diagnosis.

2.4 Patient target group

The device is intended for persons of any age who can stand independently and who do not exceed the maximum weight capacity of the device. Babies and toddlers can be weighed with the **2 in 1** function.

2.5 User qualification

Assembly Devices shipped partly assembled may only be assembled by sufficiently qualified persons (such as specialist dealers, hospital technicians or seca Service technicians).

Operation The device may only be operated by persons with formal training in the healthcare sector or in medicine.

Administration/network operation The device may only be set up and incorporated in a network by experienced administrators or hospital technicians.

2.6 Functional description

Measuring weight Weight calculation is performed by four load cells.

Measure height The height measurement is performed using a mechanical telescopic measuring rod.

**External interface module
(optional accessory)**

Data can be sent to the **seca connect 103** software via a WiFi or LAN connection with the aid of the **seca 452** external interface module (optional).

**seca connect 103
software (optional
accessory)**

The **seca connect 103** software obtains measurement data from an internal or external interface module and sends them to compatible seca measuring devices or to third-party EMR systems.

3 SAFETY PRECAUTIONS

3.1 Safety information in these instructions for use

**DANGER!**

Used to identify an extremely hazardous situation. If you fail to take note of this information, serious irreversible or fatal injuries will occur.

**WARNING!**

Used to identify an extremely hazardous situation. If you fail to take note of this information, serious irreversible or fatal injuries may result.

**CAUTION!**

Used to identify a hazardous situation. If you fail to take note of this information, minor to moderate injuries may result.

NOTICE!

Used to identify possible incorrect usage of the device. If you fail to take note of this information, you may damage the device, or the measuring results may be incorrect.

NOTE

Includes additional information about use of the device.

3.2 Basic safety information

Handling device

- ▶ Please take note of the information in these instructions for use.
- ▶ Keep the instructions for use in a safe place. The instructions for use are a component of the device and must be available at all times.
- ▶ In the interest of patient safety, you and your patients are obliged to report serious events that occur in connection with this product to the manufacturer and to the authority responsible in your country.

**DANGER!****Risk of explosion**

- ▶ Do not use the device in an environment in which one of the following gases has accumulated:
 - oxygen
 - flammable anesthetics
 - other flammable substances/air mixtures

**CAUTION!****Patient hazard, damage to device**

- ▶ Additional devices connected to medical electrical devices must provide evidence of compliance with the relevant IEC or ISO standards (e.g. IEC 60950 for data-processing devices). Furthermore, all configurations must comply with the requirements of standards for medical systems (see IEC 60601-1-1 or Section 16 of edition 3.1 of IEC 60601-1 respectively). Anyone connecting additional devices to medical electrical devices is considered a system configurator and therefore responsible for ensuring that the system complies with the requirements of standards for systems. This also applies to additional devices recommended by seca. Your attention is drawn to the fact that local laws take precedence over the above-mentioned requirements of standards. In the event of any queries, please contact your local specialist dealer or Technical Service.

**CAUTION!****Patient hazard, damage to device**

- ▶ Have servicing carried out regularly as described in the relevant section of this document.
- ▶ Technical modifications may not be made to the device. The device does not contain any user-serviceable parts. Only have servicing and repairs performed by an authorized seca service partner. You can find a service partner in your vicinity at www.seca.com or by emailing service@seca.com.
- ▶ Use only seca original accessories and spare parts, otherwise seca will not grant any warranty.

**CAUTION!****Patient hazard, malfunction**

- ▶ Keep medical electrical devices such as high-frequency surgical equipment at a minimum distance of approx. 1 meter to prevent faulty measurements.
- ▶ Keep high-frequency equipment such as cellphones at a minimum distance of approx. 1 meter to prevent faulty measurements.
- ▶ The actual transmission output of HF devices may require minimum distances of more than 1 meter. For details, go to www.seca.com.

Preventing electric shock**WARNING!****Electric shock**

- ▶ Set up devices which can be operated with a power supply unit so that the power supply socket is within easy reach and the power supply can be disconnected quickly.
- ▶ Ensure that your local electricity supply matches the details on the power supply unit.
- ▶ Never touch the power supply unit with wet hands.
- ▶ Do not use extension cables and multiple outlets.
- ▶ Ensure that cables are not crushed or damaged by sharp edges.
- ▶ Ensure that cables do not come into contact with hot objects.
- ▶ Do not operate the device at an altitude of more than 3000 m above sea level.

Preventing injuries and infections**WARNING!**
Injury from falling

- ▶ Ensure that the device is steady and level.
- ▶ Route connector cables (if present) so that neither users nor the patient can trip over them.
- ▶ Assist people with limited motor skills when they are getting up, e.g. from a wheelchair.
- ▶ Ensure that the patient does not step directly onto or off the edges of the weighing platform.
- ▶ Ensure that the patient steps onto and off the weighing platform slowly and safely.

**WARNING!**
Danger of slipping

- ▶ Ensure that the weighing platform is dry before the patient steps onto it.
- ▶ Ensure that the patient has dry feet before stepping onto the weighing platform.
- ▶ Ensure that the patient steps onto and off the weighing platform slowly and safely.

**WARNING!**
Risk of infection

- ▶ Before and after every measurement, wash your hands to reduce the risk of cross-contamination and nosocomial infections.
- ▶ Should the patient have contagious diseases, subject the device to a hygiene treatment as described in the relevant section of these instructions for use immediately afterwards.
- ▶ Ensure that the patient does not have any open wounds or infectious skin alterations which may come into contact with the device.
- ▶ Subject the device to a hygiene treatment at regular intervals.

Preventing damage to device

NOTICE!

Damage to device

- ▶ Ensure that fluids never get inside the device. These can destroy the electronics.
- ▶ Switch off the device before you disconnect the power supply unit from the power supply socket.
- ▶ If the device is not to be used for an extended period, disconnect the power supply unit from the power supply socket. Only then is the device de-energized.
- ▶ If you are not using the device for an extended period of time, remove batteries or battery packs. Only then is the device de-energized.
- ▶ Do not drop the device.
- ▶ Do not subject the device to shocks or vibrations.
- ▶ Perform a function check before each use as described in the corresponding section in this document. Do not operate the device if it is not working properly or is damaged.
- ▶ Do not place the device in direct sunlight and ensure that it is not placed in the direct proximity of a heat source. The excessive temperatures could damage the electronics.
- ▶ Avoid rapid temperature fluctuations. If the device is transported so that a temperature difference of over 20 °C occurs, the device must be left to stand for at least 2 hours before it is switched on, otherwise condensation may form; this may damage the electronics.
- ▶ Use the device only in the intended ambient conditions.
- ▶ Do not use the device over 3000 m above mean sea level. Electronic components might become damaged.
- ▶ Store the device only in the intended storage conditions.
- ▶ Use only cleaning agents and disinfectants that match the details in the section entitled "Hygiene treatment".
- ▶ Ensure that maximum capacity is not exceeded.

Handling measuring results



WARNING!

Patient hazard

To prevent misinterpretations, measuring results for medical purposes must only be displayed and used in SI units (kilograms/grams, meters/centimeters). Some devices have the option of displaying measuring results in different units. This is purely an additional function.

- ▶ Only use measuring results in SI units.
- ▶ The user takes sole responsibility for the use of measuring results in non-SI units.

NOTICE!

Inconsistent measuring results

- ▶ Before you save and continue using measured values determined using this device (e.g. in seca software or in an EMR system), ensure that the measured values are plausible.
- ▶ If measured values have been sent to seca software or to an EMR system, ensure before continuing to use them that the measured values are plausible and assigned to the correct patient.

Handling packaging material**WARNING!****Risk of suffocation**

Packaging materials made of plastic film (e.g. bags) present a risk of suffocation.

- ▶ Store packaging material out of the reach of children.
- ▶ If the original packaging material is no longer available, only use plastic bags with safety holes to reduce the risk of suffocation. Use recyclable materials if possible.

NOTE

Store the original packaging material for future use (e.g. returning for servicing).

Handling batteries and rechargeable batteries**WARNING!****Injury**

Batteries and rechargeable batteries contain harmful substances which may explode and so escape if not handled properly.

- ▶ Do not try to recharge batteries.
- ▶ Do not expose batteries/rechargeable batteries to heat.
- ▶ Do not burn batteries/rechargeable batteries.
- ▶ If harmful substances are leaking out, avoid contact with the skin, eyes, and mucous membranes. Rinse affected areas of the body with plenty of clean water and seek medical help at once.





NOTICE!**Damage to device and malfunction due to incorrect handling**

- ▶ Use only the type of battery/rechargeable battery quoted in this document.
- ▶ Always replace all batteries/rechargeable batteries at the same time.
- ▶ Do not short-circuit batteries/rechargeable batteries.
- ▶ If you do not use the device for an extended period of time, remove the batteries/rechargeable batteries. This prevents acid from leaking into the device.
- ▶ If harmful substances have penetrated the device, do not continue using it. Have the device checked by an authorized seca service partner and repaired if necessary.

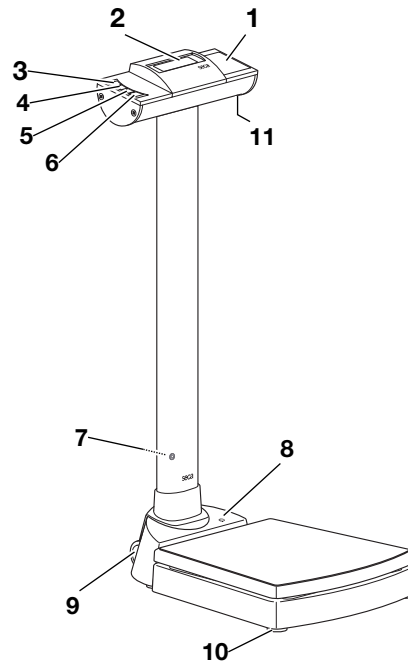
4 OVERVIEW

4.1 Controls, scale



Item	Control	Function
1	Display housing	Central control and display element
2	Display	Display element for measuring results and to configure the device
3		Switches the scale on and off
4		During weighing: <ul style="list-style-type: none"> Press briefly: Activate Hold function Press and hold: Activate 2 in 1 function In the menu: <ul style="list-style-type: none"> Select submenu, select menu item
5		During weighing: <ul style="list-style-type: none"> Press briefly: Activate BMI function Press and hold: Call up menu In the menu: <ul style="list-style-type: none"> Select submenu, select menu item
6		In the menu: <ul style="list-style-type: none"> Confirm selected menu item Save set value
7	Power supply connection	Serves to connect the optional power supply unit
8	Spirit level	Indicates whether the device is horizontal
9	Caster	Two pieces, for transporting short distances
10	Foot screw	4 pcs, for precise alignment

Item	Control	Function
11	Battery compartment	Holder for batteries

4.2 Controls measuring rod (variant-dependent)

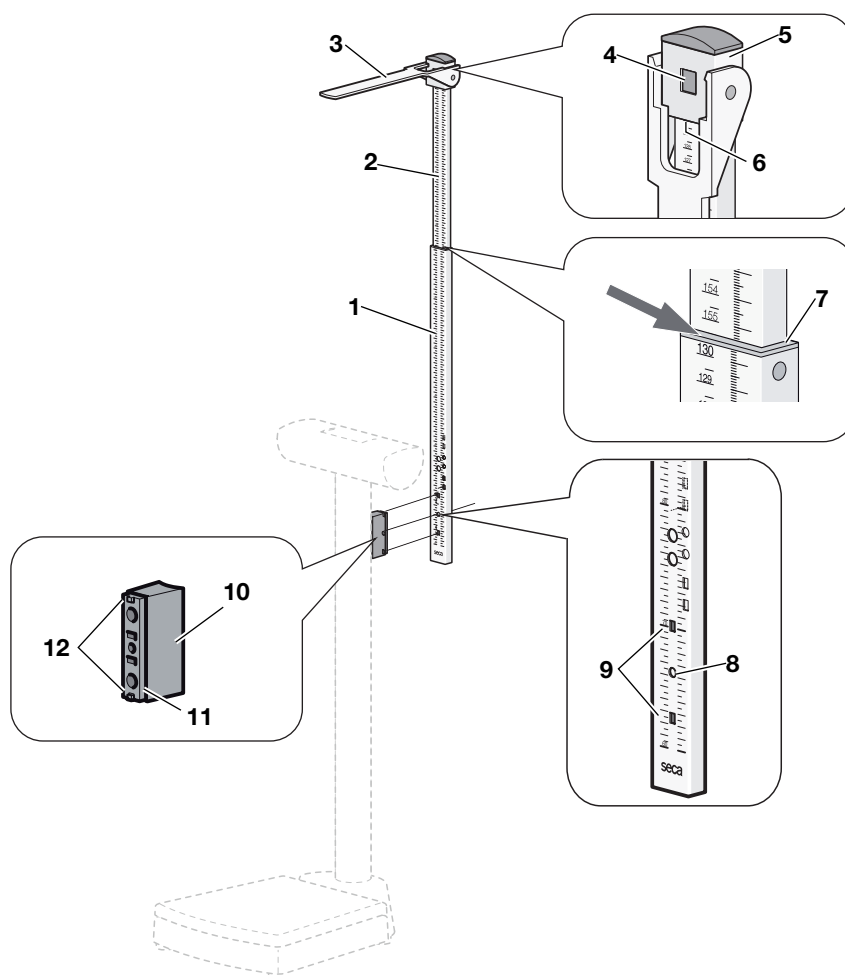

Item	Control/assembly elements	Function
1	Lower telescopic element	Measuring range 1: 60 cm – 130.5 cm
2	Upper telescopic element	Measuring range 2: 130.5 cm – 200 cm
3	Measuring flap	<ul style="list-style-type: none"> • Head stop for measuring height • Can be folded down
4	Lock	<ul style="list-style-type: none"> • Latches the head slide for measurements in measuring range 2 • Can be released to push the head slide onto the lower telescopic element (measuring range 1)
5	Head slide	<ul style="list-style-type: none"> • Latched in upper telescopic element • Is released for measurements on the lower telescopic element
6	Read-off edge 1	For measuring results in measuring range 1 (lower telescopic element)
7	Read-off edge 2	For measuring results in measuring range 2 (upper telescopic element)

Item	Control/assembly elements	Function
8	Fixing hole	The stadiometer's fixing screw is inserted through this hole
9	Guide hole	Fit the spacer's guide pins
10	Spacer	Connects the stadiometer to the scale
11	Slider	<ul style="list-style-type: none"> Installation of the spacer Adjustment of the stadiometer
12	Guide pins	<ul style="list-style-type: none"> Insert into the guide holes of the stadiometer Ensure that the stadiometer is mounted vertically











4.3 Symbols in the display





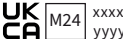





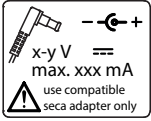



Item	Control	Function
A		Batteries are low
		Operation with power supply unit
B		Non-verifiable function active (for technical reasons, symbol is also displayed on non-verified scales)
C	kg lbs	Unit in which weight is displayed (lbs only on non-verified models)
D	→ 1 ← → 2 ←	Weighing range currently in use (only verified models)

4.4 Markings on the device and on the type plate

Markings on the device and on the type plate	
Symbol	Meaning
	Name and address of manufacturer, date of manufacture
UDI	Unique Device Identifier (product identification number)
	Article number
	Serial number
GAL	Value in m/s^2 (model-dependent) <ul style="list-style-type: none"> Gravitational acceleration on earth Depends on the intended location

Markings on the device and on the type plate	
Symbol	Meaning
ProdID	Product identification number
Mat.No.	Variant number
Approval Type	Type designation of design approval
	Follow instructions for use
	Medical electrical device, Type B
IP20	Type of protection to IEC 60529: <ul style="list-style-type: none"> • Protection against ingress of solid foreign bodies with a diameter of over 12.5 mm • Protection against access with fingers • No protection from ingress of water
e	Value in units of mass (verified models) Used to classify and verify a scale
d	Value in units of mass (non-verified models) States the difference between two consecutive display values
	Active weighing range
	Class III scale to directive 2014/31/EU
	Device complies with EU directives <ul style="list-style-type: none"> • M: Conformity label in compliance with directive 2014/31/EU for non-automatic scales (verified models) • 24: (Example: 2024) Year in which declaration of conformity was implemented and the CE-label was applied (verified models) • 0102: Notified Body for Metrology (verified models) • 0123: Notified Body for Medical Devices
	Medical device in accordance with regulation (EU) 2017/745
	Device meets the requirements of the USA and Canada. Certified and tested by a licensing laboratory (NRTL) of TÜV SÜD Product Services GmbH.
	Device complies with United Kingdom directives <ul style="list-style-type: none"> • M: Conformity label in compliance with UK directive SI 2016 no. 1152 for non-automatic scales (NAWIR) (verified models) • 24: (Example: 2024) Year in which declaration of conformity was implemented and the UKCA label was applied (verified models) • xxxx: Notified Body for Medical Devices of the United Kingdom • yyyy: Notified Body for Metrology of the United Kingdom (verified models)
 	Importer/representative in the United Kingdom: seca Ltd 40 Barn Street B5 5QB Birmingham United Kingdom
 	Importer/representative in Switzerland: seca ag (schweiz) Medizinische Waagen und Messsysteme Schönmatt Str. 2 CH-4153 REINACH

Markings on the device and on the type plate	
Symbol	Meaning
	<p>Type plate on the power supply connection socket</p> <ul style="list-style-type: none"> • Power supply voltage required in V • Maximum current consumption in mA • : Note polarity of device connector • : Operate device with direct current • : Use compatible seca power supply units only
	Do not dispose of device in household waste

Markings on the packaging	
Symbol	Meaning
	Protect from moisture
	Arrows indicate top of product Transport and store in an upright position
	Fragile, do not throw or drop
	Permitted min. and max. temperature for transport and storage
	Permitted min. and max. humidity for transport and storage
	Permitted min. and max. air pressure for transport and storage
	Open packaging here
	Packaging material can be disposed of through recycling programs

4.5 Menu structure

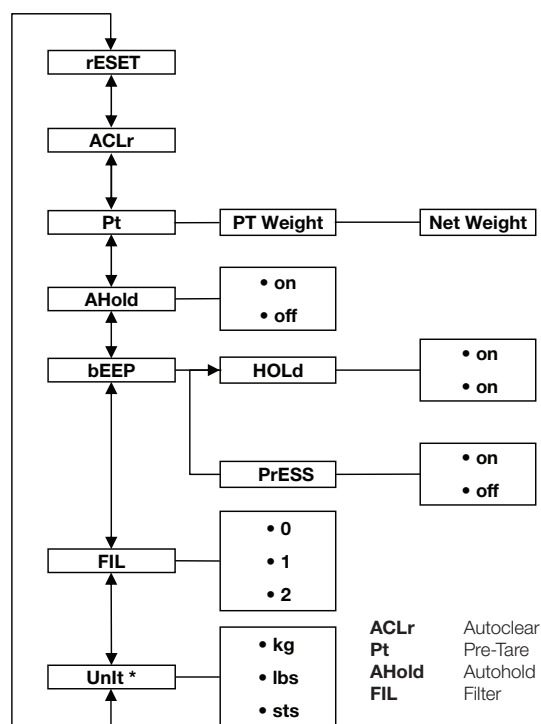

* Unverified scales

4.6 Navigating in the menu

AHOLD

FIL

FIL 0

FIL 2

1. Switch on the scale.
2. Hold down the arrow key ▼ until the menu is called up.
⇒ The last menu item selected is displayed (in this case: Autohold **AHOLD**).
3. Press one of the arrow keys until the desired menu item appears in the display (in this case: filtering **FIL**).
4. Confirm the selection by pressing the ↵ key.
⇒ The current setting for the menu item or a submenu is displayed (in this case: level **0**).
5. To change the setting, press the ▲ or the ▼ key until the desired setting is displayed (in this case: level **2**).
6. Confirm the selection by pressing the ↵ key.
⇒ The menu closes.
7. To make more settings, call up the menu again and proceed as described.

NOTE

If no key is pressed for approx. 24 seconds, the menu will close.

5 STARTING UP DEVICE

5.1 Scope of delivery, scale

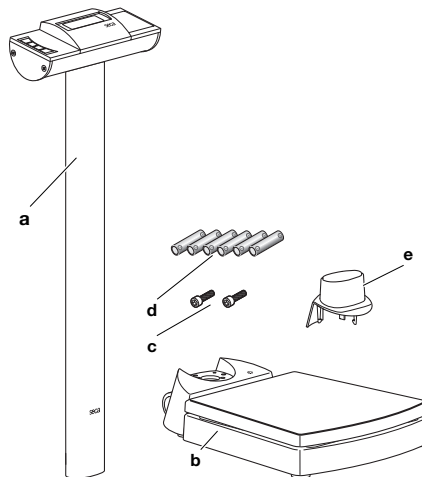

Item	Component	Pcs.
a	Column with display head	1
b	Weighing platform	1
c	Hex head socket screw SW 5	2
d	Battery, type AA/LR6, 1.5 V	6
e	Column cover	1
–	Hex socket wrench SW 5 mm, not shown	1
–	Instructions for use, not shown	1

5.2 Scope of delivery, measuring rod

- For models with the suffix “s”: included in the scope of delivery
- For models with no suffix: available separately (→ [Compatible seca products, page 35](#))

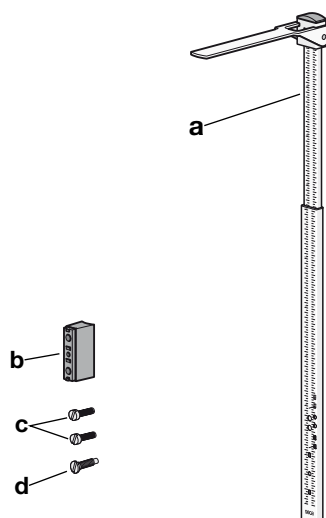

Item	Component	Pcs.
a	Telescopic measuring rod	1
b	Spacer	1
c	Screw, M5 x 30 mm, slotted head 1.2 mm	2
d	Set screw, M6 x 13 mm (total length: 22 mm), slotted head 1.2 mm	1

5.3 Fitting the column (seca 704)

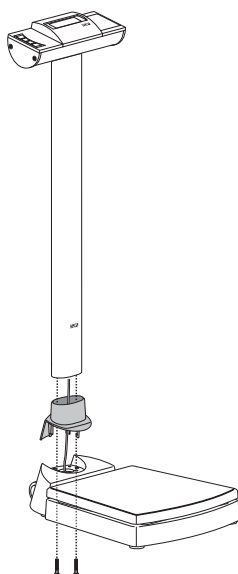

1. Slide the column cover onto the column.
2. Put the column cover on the column.
3. Put the column into the recess on the weighing platform.
4. Screw the column to the weighing platform (2 x hex head socket screw SW 5).
5. Carefully tilt the scale to one side.
6. Tighten the screws (7 Nm).

NOTICE!

Malfunction as a result of errors in installation

If cables are strained during installation, e.g. with sharp bends or kinked connectors, this may result in faulty displays and failure of the display.

- ▶ Route all cables to prevent sharp bends and kinked connectors.
- ▶ Provide strain relief by routing all cables in the relevant holders.

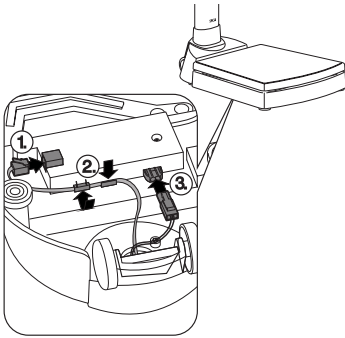

7. Connect the display cable connectors as shown in the diagram.
8. Secure the cables in the holders as shown in the diagram.
9. Carefully set the scale upright.
10. Slide the column cover down until it audibly clicks into place on the weighing platform.

5.4 Fitting the column (seca 703, seca 703 s)

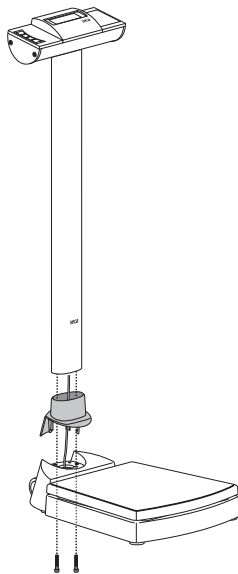

1. Slide the column cover onto the column.
2. Put the column cover on the column.
3. Put the column into the recess on the weighing platform.
4. Screw the column to the weighing platform (2 x hex head socket screw SW 5).
5. Carefully tilt the scale to one side.
6. Tighten the screws (7 Nm).

NOTICE!

Malfunction as a result of errors in installation

If cables are strained during installation, e.g. with sharp bends or kinked connectors, this may result in faulty displays and failure of the display.

- ▶ Route all cables to prevent sharp bends and kinked connectors.
- ▶ Provide strain relief by routing all cables in the relevant holders.

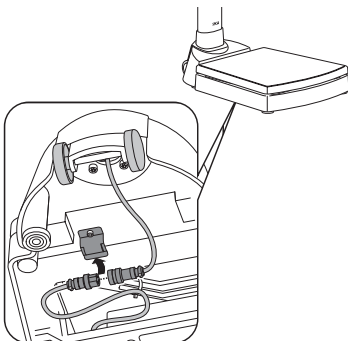

7. Connect the display cable's connector to the platform cable's connector.
8. Secure the cables in the holder on the underside of the weighing platform.
9. Carefully set the scale upright.
10. Slide the column cover down until it audibly clicks into place on the weighing platform.

5.5 Establishing power supply

Inserting batteries

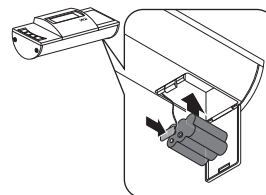

- ✓ 6 Mignon batteries, type AA, 1.5 V (included in scope of delivery)

1. Press on the latch of the battery compartment.

2. Carefully fold down the lid of the battery compartment.
3. Remove the battery holder from the battery compartment.
4. Put the batteries in the holder.

NOTE

Ensure the correct polarity of the batteries (markings in the battery holder). If **bAtt** appears in the display, you have inserted one of the batteries the wrong way round or the batteries have discharged.

5. Put the battery holder back in the battery compartment.
6. Close the battery compartment.

Connecting the power supply unit (optional)**WARNING!**

Personal injury or damage to device as a result of incorrect power supply units
Conventional power supply units may deliver a higher voltage than is indicated on them. The measuring device may overheat, catch fire, melt or short-circuit.

- ▶ Use only original seca power supply units with a controlled 12 V output voltage.

1. Plug the adapter required for your region into the power supply unit.

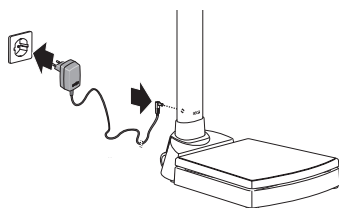
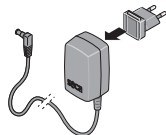

2. Insert the device connector of the power supply unit into the connecting socket of the scale.
3. Plug the power supply unit into a power supply socket.

5.6 Aligning the scale**CAUTION!****Faulty measurement as a result of devices being set up incorrectly**

Soft floors (wooden boards, for example) give under the patient's weight and falsify the measuring result. Incorrect ambient conditions or lack of alignment lead to measurement errors.

- ▶ Select a setup location with a level, stable floor in order to achieve precise measuring results.
- ▶ Use the device only in the intended ambient conditions outlined in the section entitled "Technical data".
- ▶ Align the device before using it and every time it changes location.

1. Place the scale on a firm, level surface.
2. Undo the knurled wheels.

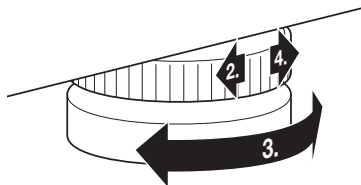

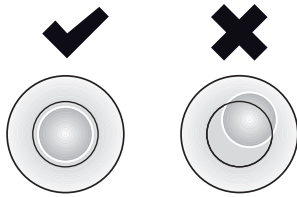

3. Align the device by turning the foot screws.
The air bubble in the spirit level must be located in the exact center of the circle.
4. Tighten the knurled wheels in the direction of the arrow.
⇒ The foot screws are secured against being adjusted.

5.7 Moving the scale

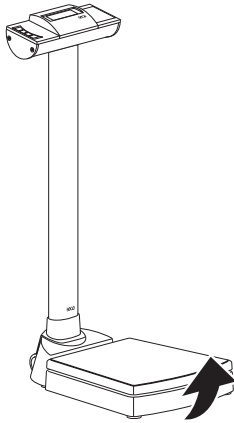

WARNING! Injury from device falling over

- ▶ Transport the scale carefully to prevent it from tipping over or colliding with other people.

1. Disconnect the power supply unit from the power supply socket.
2. Disconnect the device connector of the power supply unit from the connection socket of the scale.
3. Tilt the device until it can be moved freely on the casters.
4. Move the device in this position to the desired set up or storage location.

5.8 Fitting the measuring rod

Fitting the spacer

Proceed as follows to fit the spacer to the scale column:

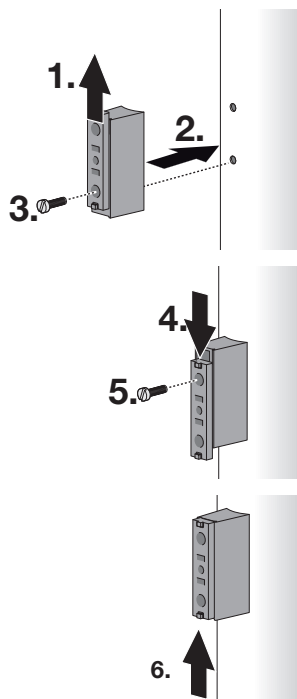

1. Move the slider until the lower hole in the spacer is exposed.
2. Align the spacer with the holes in the column.
3. Insert a screw (M5 x 30) into the lower hole of the spacer and tighten the screw.
4. Move the slider until the upper hole in the spacer is exposed.
5. Insert a screw (M5 x 30) into the upper hole of the spacer and tighten the screw.
6. Move the slider to the center position.

Fitting the stadiometer

Proceed as follows to fit the stadiometer:

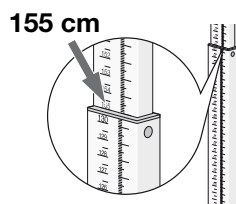

1. Pull out the upper telescopic element as far as the 155 cm mark.
⇒ The holes in the lower telescopic element are exposed.

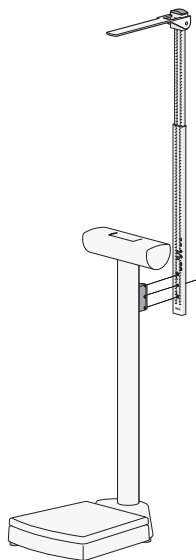

2. Align the stadiometer as shown in the adjacent diagram.

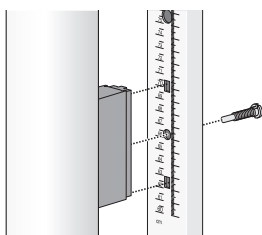

3. Place the stadiometer on the spacer as shown in the adjacent diagram.
4. Screw the stadiometer to the spacer (set screw, M6 x 13).
5. Check the installation height of the stadiometer → [Checking the installation height, page 21](#).

Checking the installation height

To obtain accurate measuring results, you must check the installation height of the stadiometer and adjust it if necessary. Proceed as follows:

1. Swing up the measuring flap.
2. Pull out the upper telescopic element as far as the 155 cm mark.
3. Measure the distance between the bottom of the measuring flap and the weighing platform, for example, using a measuring tape.

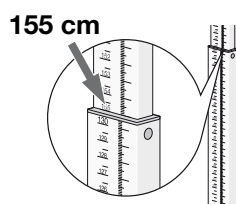

NOTE

The distance between the bottom edge of the measuring flap and the weighing platform must be 155 cm.

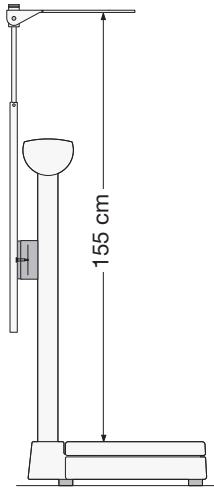

- If the measured value differs, note the difference and adjust the position of the stadiometer → [Correcting the installation height, page 22](#).

Correcting the installation height

Proceed as follows to adjust the installation height:

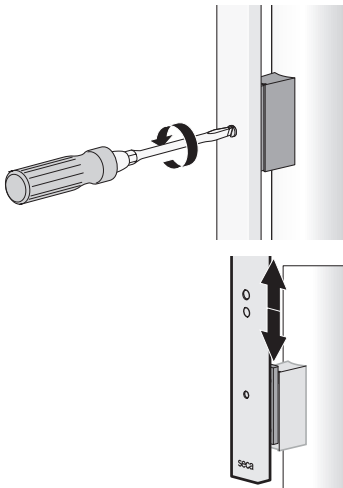

- Loosen the screw on the stadiometer slightly.
- Move the stadiometer using the spacer's slider until the target measurement of 155 cm is set.
- Check the distance between the measuring flap and the patient standing area again.
- If necessary, readjust the installation height.

NOTE

If you cannot set the target measurement, check whether you have selected the correct assembly bore on the stadiometer.

6 OPERATION



CAUTION!

Personal injury/faulty measurement

- ▶ Before using the device each time, perform a function check as described in the corresponding section of these instructions for use.

NOTICE!

Faulty measurement

Under certain conditions, part of the patient weight will not be included in the measurement. The measuring result is then incorrect.

- ▶ Set up the device so that only its foot screws are in contact with the ground.
- ▶ Set up the device so that the weighing surface is not in contact with any other objects.
- ▶ Set up the device so that the weighing platform is in free contact with the lower part of device and is not interfered with by other objects, e.g. a cable.
- ▶ During weighing, ensure that the patient does not touch the column of the device.

6.1 Weighing

Switching on the scale

- ▶ Press the  key.
 - ⇒ All the elements of the display are shown briefly, then **SECA** appears in the display.
 - ⇒ The scale is operational when **0.00** appears in the display.

Weighing a patient

- ✓ The weighing platform has no load.
- 1. Ask the patient to step onto the weighing platform.
- 2. Ask the patient not to move.
- 3. Read off the measuring result.



Weighing babies/toddlers (2 in 1)

The **2 in 1** function can be used to determine the weight of babies and toddlers. The child is held in an adult's arms during weighing to do this. Proceed as follows:

1. The weighing platform has no load.
2. Ask the adult to stand on the scale.
 - ⇒ The adult's weight is displayed.
3. Press the **▲ hold/2 in 1** key.
 - ⇒ The adult's weight is stored as the initial weight.



⇒ **0.00**, the  symbol and the **NET** message are displayed.





WARNING!

Faulty measurement as a result of initial weight changing

If the child is weighed together with a different adult, it will not be possible to determine the child's weight correctly.

- ▶ Ensure that the child is always weighed with the adult with whom the initial weight was determined.
- ▶ Ensure that the adult's weight does not change - as a result of their taking off a piece of clothing, for example.





4. Ask the adult to get onto the scale holding the child.
 - ⇒ The child's weight is displayed.
 - ⇒ The symbols  and  as well as the messages **HOLD** and **NET** are displayed.
5. To deactivate the function, press the **▲ hold/2 in 1** key or switch off the scale.

Keep the measuring result on the display (HOLD)

When the **Hold** function is activated, the weight is still displayed after the weight has been removed from the scale. This enables you to attend to the patient before recording the weight value.

- ✓ The weighing platform has no load.

1. Switch on the scale.
2. Weigh the patient as described in the section entitled → [Weighing a patient, page 23](#).
3. Briefly press the **▲ hold/2 in 1** key.
4. Wait until the weight value has stopped flashing.
 - ⇒ The  symbol and the **HOLD** message are displayed.
 - ⇒ The patient can leave the weighing platform and the weight value will continue to be displayed.
5. To deactivate the function, briefly press the **▲ hold/2 in 1** key.
 - ⇒ The  symbol and the **HOLD** message are no longer displayed.
 - ⇒ The weight value is no longer displayed.



NOTE

If the autohold function is activated, the weight value is automatically displayed permanently until the scale switches itself off or is switched off, see → [Activating Autohold function \(AHold\)](#), page 27.

Determining Body Mass Index

Body Mass Index correlates height and weight. To do this, the patient's height must be entered manually. The device calculates the BMI from the entered value and the measured weight.

✓ The weighing platform has no load.



1. Switch on the scale.
2. Briefly press the **▼ bmi/menu** key.
⇒ The message **BMI** appears.
⇒ The most recently entered height is displayed.
3. You have the following options for continuing:
 - ▶ Adopt value
 - ▶ Change value: Press the **▲** or the **▼** key
4. Confirm your setting by pressing the **↵** key.
⇒ The height entered is saved and can be called up again for calculating a new BMI.
5. Weigh the patient as described in → [Weighing a patient](#), page 23.
⇒ The patient's BMI is automatically calculated and displayed.
6. To deactivate the BMI function, briefly press the **↵** key.



Switching weighing range automatically

The scale has two weighing ranges. In weighing range 1 (→|1|←), graduations in the weight display are finer. In weighing range 2 (→|2|←), you can use the maximum capacity of the scale.

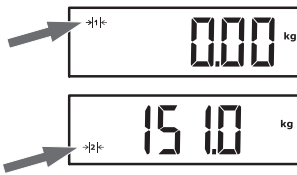

After the scale is switched on, weighing range 1 is active.

If a particular weight value is exceeded, the scale automatically switches to weighing range 2.

- ▶ To switch back to weighing range 1, completely remove the weight from the scale.
⇒ Weighing range 1 is active again.

Switching the weight unit (Unit)

You can select the unit in which weight is to be displayed.

⚠ CAUTION! Patient hazard

To prevent misinterpretations, measuring results for medical purposes must only be displayed and used in SI units (kilograms/grams, meters/centimeters). Some devices have the option of displaying measuring results in different units. This is purely an additional function.

- ▶ Only use the measuring results in SI units.
- ▶ You as the user take sole responsibility for the use of measuring results in non-SI units.

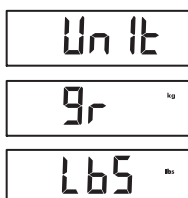

1. From the menu, select the **Unit** menu item.
2. Confirm your selection.
⇒ The current setting is displayed.
3. Select the unit in which weight is to be displayed:
 - Kilograms/grams (**gr**)
 - Pounds (**lbS**)
 - Stones (**sts**)
4. Confirm your selection.
⇒ The setting is adopted.
⇒ The menu closes.

Switching off the scale ► Press the  key.

NOTE

For battery pack/battery mode only: The device switches off automatically after a short time if there is no load on the scale.

6.2 Measuring height (variant-dependent)

Measuring heights up to 130.5 cm

To measure people with a height of up to 130.5 cm, proceed as follows:

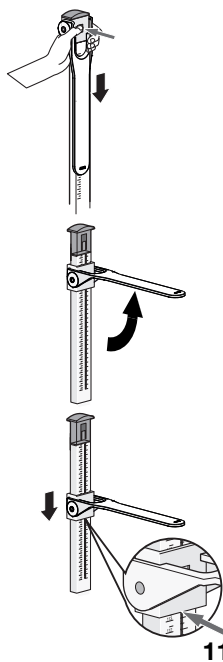

113.5 cm

1. Press the lock to release the head slide.
2. Fold up the measuring flap until it engages in a horizontal position.
3. Ask the patient to stand under the measuring flap and stand up straight.
4. Push the head slide on the lower telescopic element down until the measuring flap is in contact with the patient's head.
5. Read the measuring result off the read-off edge (read-off edge 1) of the head slide (in this case: 113.5 cm).
6. Make a note of the measuring result.
7. Ask the patient to step off the weighing platform.
8. Fold down the measuring flap.
9. Push up the head slide until it engages in the lock.

Measuring heights above 130.5 cm

To measure people with a height above 130.5 cm, proceed as follows:

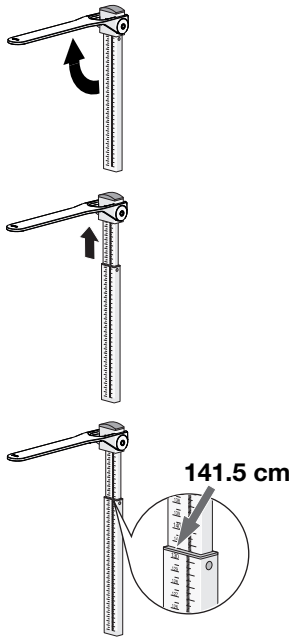

1. Fold up the measuring flap until it engages in a horizontal position.
2. Extend the upper telescopic element far enough that the patient can get under the measuring flap comfortably.
3. Ask the patient to stand under the measuring flap and stand up straight.
4. Push the upper telescopic element down until the measuring flap is in contact with the patient's head.
5. Read the measuring result off the read-off edge (read-off edge 2) of the lower telescopic element (in this case: 141.5 cm).
6. Make a note of the measuring result.
7. Ask the patient to step off the weighing platform.
8. Push the upper telescopic element into its lowest position.
9. Fold down the measuring flap.

6.3 Other functions (menu)

Deleting saved values automatically (ACLR)

Out-of-date measuring results lead to incorrect calculation of BMI. You can set the device so that the measuring results are deleted automatically after 5 minutes.

NOTE

This function is activated at the factory on some models. The function can be deactivated.



1. From the menu, select the **ACLR** menu item.
2. Confirm your selection.
⇒ The current setting is displayed.
3. Select the desired setting:
 - **On**
 - **OFF**
4. Confirm your selection.
⇒ The menu closes.

Saving additional weight permanently (Pt)

With the **Pre-Tare** function, for example, you can save a flat-rate figure for shoes and clothing and deduct this from the measuring result if a patient is weighed fully-clothed.

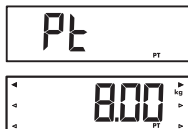

1. From the menu, select the **Pt** menu item.
2. Confirm your selection.
⇒ Arrows flash in the display.
⇒ The last additional weight saved is displayed.
3. You have the following options for continuing:
 - ▶ Adopt value
 - ▶ Change value: Press the ▲ or the ▼ key

NOTE

When you enter the value **0**, the function is switched off. The message **Pt** is no longer shown in the display.

4. Confirm your selection.



5. Ask the patient to step onto the weighing platform.
 - ⇒ The patient's weight is displayed.
 - ⇒ The saved additional weight has been deducted automatically.
6. To deactivate the function, select the **Pt** menu item from the menu again.
7. Confirm your selection.
 - ⇒ The function is deactivated.
 - ⇒ The menu closes.

NOTE

When you switch the scale off, the function is switched off. The message **Pt** is no longer displayed when you switch the scale on again.

Activating Autohold function (AHOLD)

When you activate the **Autohold** function, the measuring result is displayed for every weighing procedure after the weight has been removed from the scale. It is then no longer necessary to activate the **Hold** function manually.

NOTE

This function is activated at the factory on some models. The function can be deactivated.



1. From the menu, select the **AHOLD** menu item.
2. Confirm your selection.
 - ⇒ The current setting is displayed.
3. Select the desired setting:
 - **On**
 - **OFF**
4. Confirm your selection.
 - ⇒ The setting is adopted.
 - ⇒ The menu closes.

Activating/deactivating beeps (bEEP)

You can activate beeps for a number of device functions:



1. From the menu, select the **bEEP** menu item.
2. Confirm your selection.
3. Select a menu item:
 - **PrESS**: beep when key is pressed
 - **HOLD**: beep when weighing value is stable
4. Confirm your selection.
 - ⇒ The current setting is displayed.
5. Select the desired setting:
 - **On**
 - **OFF**
6. Confirm your selection.
 - ⇒ The setting is adopted.
 - ⇒ The menu closes.

Setting filtering (FIL)

Attenuation (**FIL**) allows you to reduce interference during weight determination. The selected setting affects the sensitivity with which the weight display reacts to patient movements and the time until the **Hold** function displays a weight value permanently (**Hold** value).

Attenuation level (FIL)	Sensitivity	Determination of Hold value
0	Sensitive	Slow
1	Medium	Medium
2	Slow	Fast

NOTE

With the **0** setting and patients who are not very steady on their feet, it is possible that no weighing value is displayed permanently despite the **Hold** function being activated.

The greatest deviation between weighing value displayed and actual value occurs at setting **2**.

1. From the menu, select the **FIL** menu item.
2. Confirm your selection.
⇒ The current setting is displayed.
3. Select a filtering level.
4. Confirm your selection.
⇒ The setting is adopted.
⇒ The menu closes.

Non-verified models: Switching the weight unit (Unit)



CAUTION! Patient hazard

To prevent misinterpretations, measuring results for medical purposes must only be displayed and used in SI units (kilograms/grams, meters/centimeters). Some devices have the option of displaying measuring results in different units. This is purely an additional function.

- ▶ Only use the measuring results in SI units.
- ▶ You as the user take sole responsibility for the use of measuring results in non-SI units.

1. From the menu, select the **Unit** menu item.
2. Confirm your selection.
⇒ The current setting is displayed.
3. Select the unit in which weight is to be displayed:
 - Kilograms/grams (**gr**)
 - Pounds (**lbS**)
 - Stones (**sts**)
4. Confirm your selection.
⇒ The setting is adopted.
⇒ The menu closes.

Restoring factory settings (rESEt)

You can restore the factory settings for the functions below:

Function	Factory setting
Autohold (AHOLd), verified model	OFF
Autohold (AHOLd), non-verified model	On
Acoustic signal (PrESS)	OFF
Acoustic signal (HOLd)	On
Attenuation (FIL)	0
Autoclear (ACLr)	On
Pre-tare (Pt)	0 kg
Height for Body Mass Index (bMi)	170 cm
Unit, weight (Unit)	kg (gr)

1. From the menu, select the **rESEt** menu item.
2. Confirm your selection.
⇒ The menu closes.
3. Switch off the scale.
⇒ Factory settings are restored and are available when the scale is switched on.

7 HYGIENE TREATMENT

WARNING! **Electric shock**

The device is not de-energized when the on/off button is pressed and the display goes out. Use of fluids on the device may cause an electric shock.

- ▶ Before each hygiene treatment, ensure that the device is switched off.
- ▶ Disconnect the power supply connector before each hygiene treatment.
- ▶ Take the batteries out of the device before every hygiene treatment.
- ▶ Ensure that no fluids penetrate the device.

WARNING! **Risk of infection**

- ▶ Subject the device to a hygiene treatment at regular intervals as described in this section.

NOTICE! **Damage to device**

Unsuitable cleaning agents and disinfectants may damage the sensitive surfaces of the device and impair its operability.

- ▶ Do not use aggressive or abrasive cleaning agents.
- ▶ Do not use organic solvents (e.g. white spirit or petroleum spirit).

7.1 Cleaning

- ▶ If required, moisten a soft cloth with a mild soap solution and wipe the device over with it.

7.2 Disinfecting

1. Disinfect the device at regular intervals with a disinfectant suitable for sensitive surfaces and acrylic glass (e.g. 70 % ethanol).
2. Follow the instructions for use of the disinfectant.
3. Disinfect the device:
 - ▶ Moisten a soft cloth with disinfectant and wipe down the device with it.
 - ▶ Comply with the intervals, see table:

Interval	Component
Before and after each measurement	<ul style="list-style-type: none"> • Weighing platform • Head slide with measuring flap (variants with measuring rod)
As required	<ul style="list-style-type: none"> • Column and display head of scale • Telescopic elements of the measuring rod (variants with measuring rod)

7.3 Sterilizing

The device must not be sterilized.

8 FUNCTION CHECK

- ▶ Perform a function check before each use.

A complete function check includes:

- A visual inspection for mechanical damage
- A test of the alignment of the device
- A visual and function check of the display elements
- A function check of all the controls shown in the section entitled "Overview"
- A function check of the optional accessories

If you find faults or deviations during the function check, first try to remedy the fault with the aid of the "Troubleshooting" section in this document.



CAUTION! Personal injury

If you find faults or deviations during the function check which you are unable to remedy with the aid of the "Troubleshooting" section in this document, you must not use the device.

- ▶ Have the device repaired by seca Service or an authorized service partner.
- ▶ Follow the section entitled "Servicing" in this document.

9 TROUBLESHOOTING

NOTICE! Malfunction

If the device is equipped with the optional **seca 452** external interface module and is connected to the **seca connect 103** software, error messages and error symbols which are not described here may occur.

- ▶ Follow the system instructions for use for **seca 103/452**.

Fault	Cause	Remedy
No weight is displayed with a load on the scale.	The device has no power supply.	<ul style="list-style-type: none"> • Switch on device. • In battery mode: Insert batteries. • In power supply operation: Connect the power supply unit.
 is displayed.	Battery voltage is dropping.	Insert new batteries as soon as possible
bAtt is displayed.	The batteries have discharged.	Insert new batteries
0.00 is not displayed before weighing takes place.	A load was already on the device before it was switched on.	<ul style="list-style-type: none"> • Remove the load from the device. • Switch off the device, then switch it back on again.
----- is displayed before weighing takes place.	A load was already on the device before it was switched on.	<ul style="list-style-type: none"> • Remove the load from the device. • Switch off the device, then switch it back on again.
The weight display flashes.	Consistent weight value not yet detected.	<ul style="list-style-type: none"> • One of the following functions is active: Hold, Autohold, 2 in 1. Wait until the device has detected a consistent weight value. The display stops flashing. • Take the load off the device, wait until 0.00 is displayed and measure again.

Fault	Cause	Remedy
Implausible measuring results.	Patient moved too much during the measurement.	Take the load off the device, wait until 0.00 is displayed and repeat the measurement procedure.
One display segment is displayed continuously or not at all.	The display is defective.	Inform seca Service.
StOP is displayed.	Maximum capacity has been exceeded.	Remove the load from the device.
tEMP is displayed.	The ambient temperature of the scale is too high or too low.	<ul style="list-style-type: none"> Operate the device only in the intended ambient conditions (see "General technical data"). After transporting or storing the device, wait approx. 15 minutes before switching it on.
The device no longer reacts when keys are pressed.	Device is in an undefined state following implausible input.	<ul style="list-style-type: none"> Take power supply unit out of the power supply socket. Wait approx. 1 minute. Plug the power supply unit into the power supply socket; the scale and the multifunctional display will switch on automatically.
	The keypad is defective.	Inform seca Service.
The height measurement does not yield a plausible value.	Measuring rod installed at the wrong height	Check installation height Correct the installation height if required
	Measuring result read off incorrectly	<ul style="list-style-type: none"> Use the correct read-off edge for the current measuring range Read off decimal places for the current measuring range in the correct direction
	Patient in wrong position/posture	Correct patient's position/posture

10 SERVICING

10.1 Verified scales



CAUTION!

Faulty measurements as a result of verification being performed poorly or not at all

- ▶ Have verification performed only by authorized persons.
- ▶ Always have verification performed if one or more quality seals are damaged.

seca recommends having your device serviced prior to verification.



CAUTION!

Faulty measurements as a result of poor servicing

- ▶ Have servicing and repairs carried out exclusively by seca Service or an authorized service partner.
- ▶ You can find your local service partner at www.seca.com.

Have authorized persons perform verification in line with national legal regulations.

Verification is necessary whenever one or more quality seals are damaged or the contents of the verification counter no longer match the number on the applicable verification sticker. If quality seals are damaged, contact seca Service directly.

Verifications may only be performed by authorized agencies. To guarantee this, the scale is equipped with a verification counter which records each change in verification-related data.

If you want to check whether the scale has been properly verified, proceed as follows:

✓ The device is switched off.

1. Ensure that the device is switched off.

2. Press and hold any key and start the scale.

⇒ The current content of the verification counter flashes in the display for a few seconds.

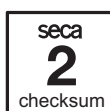

3. Compare the content of the verification counter output with the number given on the verification counter seal.

Both numbers have to match for the verification to be valid. If the verification sticker and the verification counter do not match, the scale must be verified. Please contact your service partner or seca Service. Once the scale has been verified, a new, updated verification counter sticker is used to identify the verification counter reading. The person authorized to perform verification secures this verification with an additional seal. The verification counter sticker can be ordered from seca Service.

10.2 Non-verified scales

The product needs to be set up carefully and serviced regularly. Depending on how frequently the product is used, seca recommends servicing at intervals of 3 to 5 years.



CAUTION!

Faulty measurements as a result of poor servicing

- ▶ Have servicing and repairs carried out exclusively by seca Service or an authorized service partner.
- ▶ You can find your local service partner at www.seca.com.

10.3 Measuring rod

The measuring rod does not require any servicing.



If something does happen to malfunction, servicing and repairs should be performed by seca Service or an authorized service partner. You can find a service partner in your vicinity at www.seca.com or by sending an email to service@seca.com

11 TECHNICAL DATA

11.1 General technical data

Parameter	Value
Dimensions, scale	
• Depth	520 mm
• Width	360 mm
• Height	930 mm
Dimensions, scale with stadiometer	
• Depth	543 mm
• Width	360 mm
• Height (stadiometer retracted)	1406 mm
• Height (stadiometer extended)	2101 mm

17-10-07-683-002-2026-03S

Parameter	Value
Weight <ul style="list-style-type: none"> • Scale • Scale with stadiometer 	approx. 17.0 kg approx. 17.7 kg
Height of digits, display	25 mm
Ambient conditions, operation <ul style="list-style-type: none"> • Temperature • Air pressure • Humidity 	+10 °C to +40 °C / +50 °F to 104 °F 700 – 1060 hPa 30 % – 80 % no condensation
Ambient conditions, storage/transport <ul style="list-style-type: none"> • Temperature • Air pressure • Humidity 	-10 °C to +65 °C / +14 °F to 149 °F 700 – 1060 hPa 0 % – 95 % no condensation
Medical device in accordance with regulation (EU) 2017/745	Class I with measuring function
IEC 60601-1: Medical electrical device, Type B	
Type of protection in accordance with IEC 60529	IP20
Duty cycle	Continuous duty
Service life, from commissioning ^a	at least 10 years
Application parts according to IEC 60601-1	Weighing platform, display housing, film keypad, display
Batteries <ul style="list-style-type: none"> • Supply voltage • Battery type • Maximum running time 	9 V 6 x type AA 1.5 V approx. 5600 weighing operations
Power supply unit, optional <ul style="list-style-type: none"> • Supply voltage • Current consumption • Insulated device, protection class II (IEC 60601-1) • Mains voltage • Power supply frequency 	12 V approx. 25 mA  100 V – 240 V 50 Hz – 60 Hz

^a Minimum service life when used as intended and serviced in a timely manner. seca products usually have a significantly longer service life.

11.2 Weight measurement

Verified model	
Verification in line with directive 2014/31/EU	Class III
Maximum capacity <ul style="list-style-type: none"> • Weighing range 1 • Weighing range 2 	150 kg 300 kg
Minimum capacity <ul style="list-style-type: none"> • Weighing range 1 • Weighing range 2 	0 kg 2 kg
Graduation <ul style="list-style-type: none"> • Weighing range 1 • Weighing range 2 	50 g 100 g
Tare range	300 kg (subtractive)

Verified model	
Accuracy on initial verification	
• Weighing range 1: < 25 kg	± 25 g
• Weighing range 1: 25 kg to 100 kg	± 50 g
• Weighing range 1: 100 kg to 150 kg	± 75 g
• Weighing range 2: < 50 kg	± 50 g
• Weighing range 2: 50 kg to 200 kg	± 100 g
• Weighing range 2: 200 kg to 300 kg	± 150 g

Non-verified model	
Maximum capacity	
• Partial weighing range 1	150 kg/330 lb/24 st
• Partial weighing range 2	300 kg/660 lb/47 st
Minimum capacity	2 kg
Graduation	
• Partial weighing range 1	50 g/0.1 lb
• Partial weighing range 2	100 g/0.2 lb
Tare range	300 kg/660 lb/47 st (subtractive)
Accuracy	
• < 70 kg	± 100 g
• 70 kg to 300 kg	± 0.15 %
• < 150 lb	± 0.2 lb
• 150 lb to 660 lb	± 0.15 %
• < 11 st	± 0.2 lb
• 11 st to 48 st	± 0.15 %
At ambient temperature of 20° C and humidity of 45 %	

11.3 Height measurement

Measuring range, graduation, accuracy	
Measuring range 1	60 cm – 130.5 cm (23.6 inch – 51.4 inch)
Measuring range 2	130.5 cm – 200 cm (51.4 inch – 78.7 inch)
Graduation	1 mm (1/8 inch)
Accuracy	± 5 mm

12 OPTIONAL ACCESSORIES AND SPARE PARTS

Accessory/spare part	Article number
“Panda bear” figure seca 459	459 0000 009
Power supply unit with Euro connector: 230 V~ /50 Hz/ 12 V= / 130 mA	68 32 10 252
Switch-mode power supply unit with adapters: • Input: 100 V – 240 V~, 50 Hz – 60 Hz • Output: 12 V= / 0.98 A	68 32 10 265 009
Switch-mode power supply unit with adapters: • Input: 100 V – 240 V~, 50 Hz – 60 Hz • Output: 12 V= / 0.6 A	68 32 10 270 009

17-10-07-683-002-2026-03S

Accessory/spare part	Article number
Accessories for integration via WiFi/LAN <ul style="list-style-type: none"> External interface module seca 452 Software seca connect 103 Barcode scanner 	452 0050 009 Will be provided in the course of integration projects Cannot be ordered through seca; for recommendations, see System instructions for use for seca 103/452

13 COMPATIBLE SECA PRODUCTS

Product	Article number
Telescopic measuring rod seca 220 <ul style="list-style-type: none"> cm cm/inch 	220 17 14 004 220 18 14 004

14 DISPOSAL

14.1 Disposing of the device



Do not dispose of the device in your household waste. The device must be properly disposed of as electronic scrap. Follow your respective national regulations. For more information, please contact seca Service or an authorized service partner.

14.2 Disposing of batteries and rechargeable batteries



Do not dispose of used batteries and rechargeable batteries in household waste, regardless of whether they contain harmful substances or not. As a consumer, you are legally obliged to dispose of batteries and rechargeable batteries via local authority collection points or trade collection points. Only dispose of batteries and rechargeable batteries once they are completely discharged.

15 WARRANTY

There is a two-year warranty period from delivery for defects attributable to poor materials or workmanship. All movable parts, e.g. batteries, cables, power supply units, rechargeable batteries etc. are exempt. Defects which come under the warranty will be repaired for the customer free of charge against proof of purchase. Additional claims cannot be considered. Costs of transport to and from seca are the responsibility of the customer if the device is located somewhere other than the customer's headquarters. In the event of transport damage, claims under warranty can only be made if the complete original packaging was used for transport and the device was secured and fastened in it according to its originally packaged condition. You should therefore keep all packaging parts.

The warranty will be voided if the device is opened by persons not expressly authorized by seca to do so.

In the event of a warranty issue, please contact your local seca office or the dealer from whom you ordered the product.

16 DECLARATION OF CONFORMITY



seca gmbh & co. kg hereby declares that the product complies with the terms of the applicable European directives and regulations. The unabridged declaration of conformity can be found at www.seca.com.

Medical Measuring Systems and Scales since 1840

seca gmbh & co. kg
Hammer Steindamm 3–25
22089 Hamburg · Germany
T +49 40 20 00 00 0
F +49 40 20 00 00 50
E info@seca.com

seca operates worldwide with headquarters
in Germany and branches in:

[seca france](#)
[seca united kingdom](#)
[seca north america](#)
[seca schweiz](#)
[seca zhong guo](#)
[seca nihon](#)
[seca mexico](#)
[seca austria](#)
[seca polska](#)
[seca middle east](#)
[seca suomi](#)
[seca américa latina](#)
[seca asia pacific](#)
[seca danmark](#)
[seca benelux](#)
[seca lietuva](#)

and with exclusive partners in
more than 110 countries.

All contact data at [seca.com](https://www.seca.com)